

Agilent 89600 Series Vector Signal Analyzers

Product Note

Making measurements on 802.11a and HiperLAN2 OFDM signals using Agilent PSA series performance spectrum analyzers as downconverters

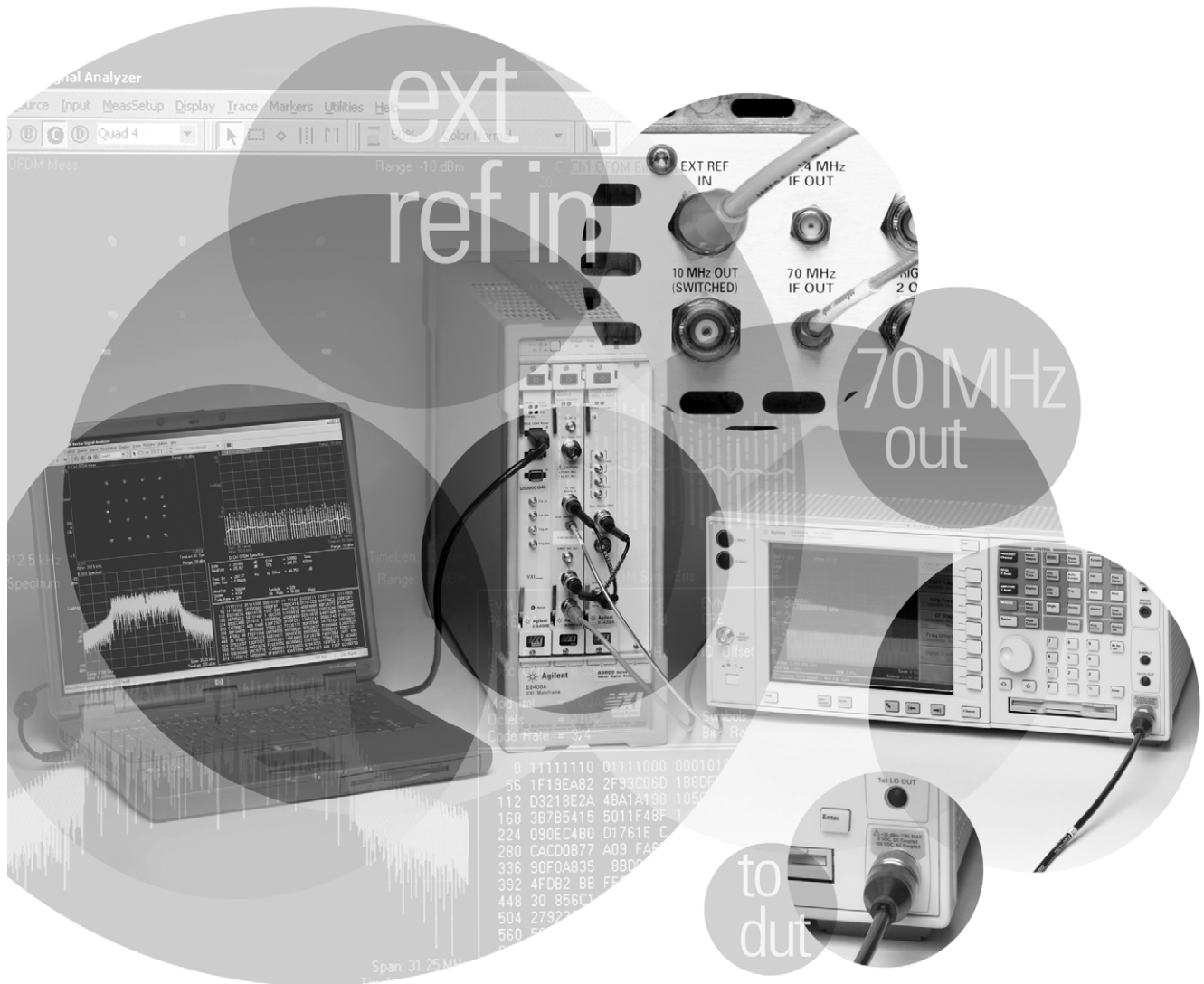

Introduction

This product note characterizes the combined performance of an E4440A, E4443A or E4445A PSA series performance spectrum analyzer and an 89600 series vector signal analyzer (VSA). This combination adds the flexible digital demodulation and analysis capabilities of the VSA to the higher frequency coverage and excellent spectrum analysis capability of the PSA series analyzer. Together these products provide superior spectrum and modulation analysis of 802.11a and HiperLAN2 OFDM signals.

Overview

The PSA series analyzers are full-featured, high-performance spectrum analyzers. They provide fast, low-level spur search capability, a high usable dynamic range, low phase noise, high accuracy and fine resolution.

Configured with Option H70, a PSA series analyzer provides its 70 MHz IF to the 89611A IF vector signal analyzer. This VSA digitizes and stores the IF signal, making it available for analysis by the 89601A VSA software running on a user-supplied PC.

Alternatively, users may take the 321.4 MHz output from a standard PSA series analyzer and input this directly to the 89640A dc to 2.7 GHz vector signal analyzer running the 89601A VSA software.

The 89601A vector signal analyzer software is the heart of the 89600 series vector signal analyzers. This

software provides flexible tools that can demodulate and analyze even the most advanced digitally modulated signals, including those not defined by an established standard. Configured with Options AYA (vector modulation analysis) and B7R (802.11a modulation analysis), the 89601A can demodulate to the bit level for all of the modulation formats allowed by 802.11a. New displays, such as a compound constellation display format, and new measurements, such as common pilot error, provide you with insight into your circuit's or system's performance.

The software also provides signal capture and analysis features, capability to download signal capture files for playback through signal generators and high-speed spectrogram displays.

In the PSA series Option H70/89611A combination, the digital demodulation and analysis tools of the 89601A VSA software complement the excellent spectrum analysis performance of the PSA series analyzer. The 89601A software runs on a PC connected to the hardware portion of the 89611A via an IEEE 1394 interface, and provides hardware control and displays of complete results along with modulation analysis. The controls and display on the spectrum analyzer can be disabled while operating with the 89601A software.

The combination can measure active signals or signals captured and recorded to the vector signal analyzer's memory. You also have the full spectrum analysis capability of the PSA series analyzer. Switching between the two modes is done using a quick disconnect/restart menu selection in the 89601A GUI (graphical user interface).

Configuration overview

To analyze 802.11a signals with the 89601A VSA software, you will need one of these two configurations:

- a PSA series performance spectrum analyzer with Option H70
- the 89611A IF vector signal analyzer, which includes the 89601A vector signal analyzer software with Option 100, Option AYA (vector modulation analysis) and Option B7R (802.11a and HiperLAN2 OFDM modulation analysis)
- a PC with an empty slot to accommodate the IEEE 1394 interface card.

OR

- a PSA series performance spectrum analyzer
- the 89640A dc to 2.7 GHz vector signal analyzer, including the 89601A vector signal analyzer software with Option 100, Option AYA (vector modulation analysis) and Option B7R (802.11a and HiperLAN2 OFDM modulation analysis)
- a PC with an empty slot to accommodate the IEEE 1394 interface card.

Detailed requirements for each item in both of these configurations are provided in Appendix 1.

PSA series performance spectrum analyzer with Option H70 (70 MHz IF output)

When the PSA series analyzer with Option H70 is being controlled by 89600 series VSA software, users have control of the following features of the spectrum analyzer using the software:

Frequency: The center frequency will be displayed on the 89600 series VSA software GUI.

Span: 36 MHz. This takes advantage of the PSA series analyzer's wideband IF architecture.

Input attenuator and ADC gain: available indirectly through the input range feature of the 89600 series VSA software

Triggering: IF magnitude, external front/rear, hold-off, level, delay and slope

External reference: 10 MHz (may be input to the 89611A or the spectrum analyzer)

Calibration

Overload detection

In addition, you can gain immediate, direct access to all of the PSA series spectrum analyzer's features by using the **Disconnect** capability on the VSA software's control menu.

PSA series analyzer with 89640A

When a PSA series analyzer is used to provide a 321.4 MHz output to the 89640A VSA, no control of the PSA series analyzer is provided. The user must control the spectrum analyzer manually.

VSA software features

When the 89600 series VSA software is used with a PSA series analyzer, almost all of the features of the software and its options are available.

This includes:

- Recording of extended time waveforms, allowing you to re-analyze signals and store them for future comparisons
- Complete set of of vector signal analysis and modulation analysis measurements and results
- Unique OFDM displays for error vector and time, allowing you to quickly troubleshoot your IEEE 802.11a or HiperLAN2 system
- Flexible marker capabilities, including time gating, integrated band power, and offset (delta) markers
- Flexible displays, including multiple trace displays, spectrogram, constellation, eye diagram, and error screens with powerful scaling
- Link to the Agilent ESG-series signal source for integrated control of source signals
- Complete save and recall of your signals, trace data, and measurement screens
- Easy cut and paste to other PC applications

The 89600 VSA software's swept spectrum application is not supported.

Vector signal analysis only

When a PSA series analyzer is used as a downconverter, the 89600 series VSA software supports only a single application for Microsoft® Windows NT® or Windows® 2000 – the vector signal analyzer application. This application performs vector analysis of complex signals in the time, frequency and modulation domains.

Specifications for the PSA series analyzers and the 89611A or 89640A VSA are found in the data sheets for these products. However, the following nominal values³ may be useful when making your WLAN measurements.

Except as noted, nominal values apply within the following frequency ranges:

Band 1	E4440A	10 MHz – 26.5 GHz
	E4443A	10 MHz – 6.7 GHz
	E4445A	10 MHz – 13.2 GHz
Band 2		30 Hz–36 MHz

Note: For more information, see the 89611A data sheet (literature number 5988-4092EN).

Frequency

Frequency range

Band 1	
E4440A	10 MHz – 26.5 GHz ¹
E4443A	10 MHz – 6.7 GHz ¹
E4445A	10 MHz – 13.2 GHz ¹
Band 2 (all models)	0 - 36 MHz

Frequency spans	<1Hz to 36 MHz ²
------------------------	-----------------------------

Center frequency tuning resolution	1 mHz
---	-------

Frequency points per span

Calibrated points	51-102,401
Displayable points	51-131,072

Frequency accuracy (with 89600 series VSA providing reference)

Frequency accuracy is the sum of initial accuracy, aging, and temperature drift (ppb = parts per billion)

Initial accuracy	100 ppb
Aging	1 ppb/day 100 ppb/year
Temperature drift	50 ppb, 0 – 50° C

1. In the vector signal analyzer application, 10 MHz is the minimum center frequency. With appropriate choice of frequency span, frequency coverage extends down to 30 Hz.
2. Overrange provided to 37.11 MHz.
3. Nominal values indicate expected performance, or describe product performance that is useful in the application of the product, but are not covered by the product warranty.

Amplitude

Amplitude accuracy

Input range

Full-scale range

Band 1	-34 dBm to +20 dBm in 5 dB steps
Band 2	-30 dBm to +20 dBm in 5 dB steps

Amplitude accuracy

Accuracy values apply with flat-top window selected. Amplitude accuracy is the sum of absolute full-scale accuracy and amplitude linearity.

Absolute full-scale accuracy

Band 1	
The system can be calibrated using the external RF calibration capability of 89600 series VSAs. See the online Help for details.	
Band 2	
0-50° C	±0.8 dB

Repeatability

Band 1	± 0.25 dB
--------	-----------

Flatness

Frequency response across the measurement span.

Band 1	
(Nominal, with center frequency in the range 5 – 6 GHz, BW = measurement bandwidth)	
± 5 MHz BW	±1.0 dB
± 9 MHz BW	±1.25 dB
Band 2	±0.2 dB

Repeatability

Applies for signals between 5 and 6 GHz, when the user tunes to any frequency, tunes to the extreme of this range, and then tunes back to the original frequency.

Band 1	
±5 MHz BW	±0.4 dB
±9 MHz BW	±0.4 dB

Time domain information

Baseband versus zoom measurements

These two signal processing modes affect the appearance and the duration of input waveforms as they are captured and displayed on the 89600 series VSA display.

Most 89600 series measurements are made in the zoom mode, which has a non-zero start frequency. In this mode, the time domain display shows a complex envelope representation of the input signal; that is, the magnitude and phase of the signal relative to the analyzer's center frequency. This provides powerful capability to examine the baseband components of a signal without demodulating it.

Baseband mode refers to the special case where the measurement span begins at 0 Hz. Here the input signal is directly digitized, and the waveform display shows the entire signal (carrier plus modulation), very much as an oscilloscope would.

Time waveform accuracy

See "Amplitude accuracy"

Time record characteristics

In the 89600 series VSA application, measurements are based on time records; for example, blocks of waveform samples from which time, frequency and modulation domain data is derived. Time records have these characteristics:

Time sample resolution

$= 1/(k \times \text{span})$,
where $k=2.56$ for time data = baseband
and $k=1.28$ for time data = zoom

Time record length

$= (\text{number of frequency points}-1)/\text{span}$
with RBW mode set to arbitrary, auto-coupled

Time gating

Provides time-selective frequency-domain analysis on any input or analog demodulated time-domain data. When gating is enabled, markers appear on the time data; gate position and length can be set directly. Independent gate delays can be set for each input channel (2-channel baseband configuration only). See time specifications for main time length and time resolution details.

Time gate length, maximum

Main time length

Time gate length, minimum

= window shape / (0.3 x freq. span)
where window shape is equal to:
Flat-top window 3.8
Gaussian-top window 2.2
Hanning window 1.5
Uniform window 1.0

Band-limited step response

(-22 dBm range)

Rise time = 109 ns, fall time = 130 ns

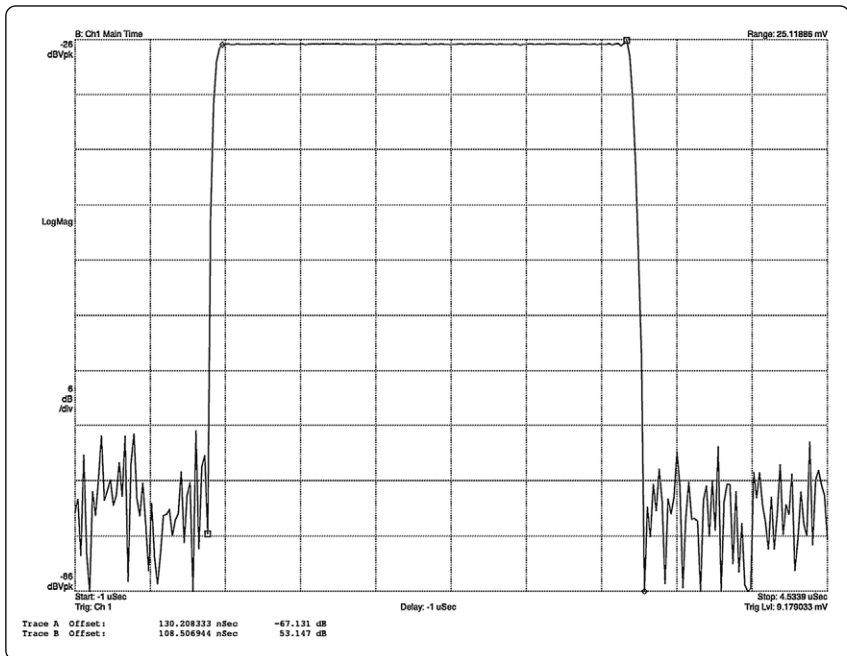

Time capture length versus span

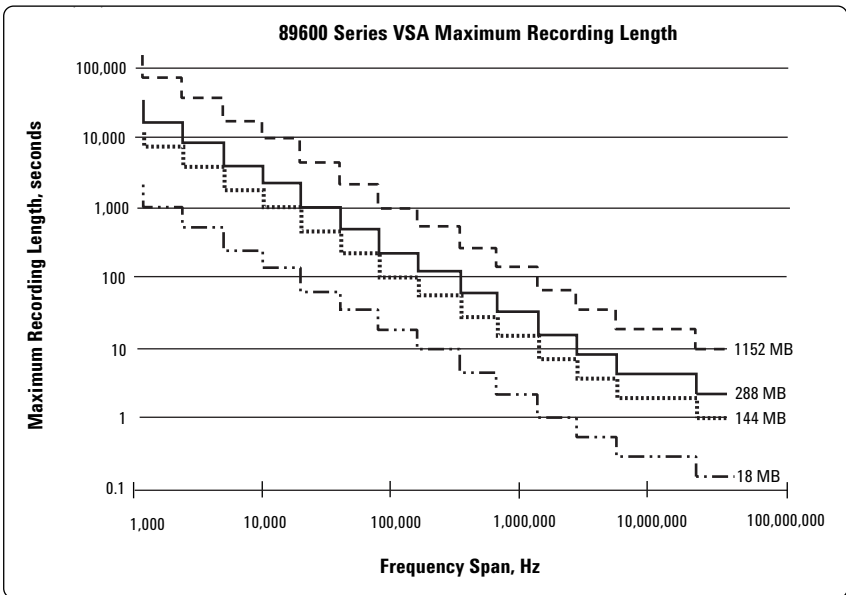

Power measurements

Power measurement accuracy:

See "Amplitude accuracy" specifications

Bandpower measurements

Channel power measurements can be easily set up using bandpower markers, or direct entry of band edge parameters. Band power markers can be placed on any time, frequency, or demodulated trace for direct computation of band power, rms square root (of power), C/N or C/NO, computed within the selected portion of the data.

Complementary cumulative distribution function

The complementary cumulative density function (CCDF) measurement is a statistical power measurement. It can be performed only on time domain data. As its name suggests, CCDF is the complement of CDF, and is defined as follows:

$$\begin{aligned} \text{CDF}(K) &= \text{Probability}(x \leq K) \\ \text{CCDF}(K) &= \text{Probability}(x \geq K) \end{aligned}$$

CCDF provides better resolution than CDF for low probability signals, especially when log format is used for the y-axis. The analyzer plots CCDF using units of percent (%) for the y-axis and power (dB) for the x-axis. Power on the x-axis is relative to the signal average power, so 0 dB is the average power of the signal. Therefore, a marker readout of

Trace A Marker 12% 2 dB

means there is a 12% probability that the signal power will be 2 dB or more above the average power.

CCDF is a useful means of evaluating component performance and verifying system behavior when the signals of interest are noise-like, such as digitally modulated OFDM signals.

Measurement, display and control

Peak power measurements

via marker function

Power measurements on a burst

Time- and frequency-selective power measurements, including bandpower and CCDF measurements, are possible using the time gating markers. For more information, see the time gate specifications.

Triggering

Trigger types	Free run, channel, IF magnitude, external
Pre-trigger delay resolution	Same as time capture sample resolution
Pre-trigger delay range	Same as time capture length
Post-trigger delay resolution	Same as time capture sample resolution
Post-trigger delay range	0 to $2^{30} - 1$ time samples ⁴

IF trigger

Used to trigger on in-band energy, where the trigger bandwidth is determined by the measurement span (rounded to the next higher cardinal span).

Amplitude resolution	<0.5 dB
Amplitude ranges	>3 dBfs to <-70 dBfs Usable range is limited by the total integrated noise in the measurement span
IF trigger hysteresis	1.5 dB

Trigger hold-off

Used to improve trigger repeatability on TDMA and other bursted signals. Trigger hold-off prevents re-triggering of the analyzer until a full hold-off period has elapsed with no signals above the trigger threshold.

Hold-off resolution	Same as time capture sample resolution
Hold-off range	0- $2^{24} - 1$ time samples ⁴

External trigger

Works with analog and TTL signals

Type	ac-coupled comparator
Minimum pulse width	>300 ns
Minimum pulse amplitude	>100 mV
Slope	Positive, negative
Input impedance	1 k Ω

Averaging

Number of averages, maximum	>10 ⁸
Overlap averaging	0% to 99.99%
Average types	rms (video), rms (video) exponential, peak hold, time, time exponential

4. Time sample length is a function of measurement span, as described under "Time domain information." In actual operation, trigger parameters are set and displayed in time units (seconds).

Display formats

Trace data	Vector signal analysis (demodulation OFF)	Vector signal analysis (analog demodulation)	Vector modulation analysis (Option AYA, required for Option B7R)	802.11a OFDM and HiperLAN2 modulation analysis (Option B7R)
Autocorrelation	•	•		
Complementary cumulative distribution function	•	•		
Cumulative distribution function	•	•		
Channel frequency response			•	•
Common pilot error				•
Correction	•	•	•	•
Error vector spectrum			•	•
Error vector time			•	•
RMS error vector time				•
RMS error vector spectrum				•
Equalizer impulse response			•	•
Gate time	•	•		
Instantaneous main time	•	•		
Instantaneous spectrum	•	•	•	•
IQ mag error			•	
IQ measurement				•
IQ measurement spectrum			•	
IQ measurement time			•	
IQ phase error			•	
IQ reference				•
IQ reference spectrum			•	
IQ reference time			•	
Main time	•	•		
Probability density function	•	•		
Power spectral density	•	•		
Search time			•	•
Spectrum	•	•	•	•
Symbols/errors			•	•
Time			•	•

Option B7R
802.11a OFDM and HiperLAN2
modulation analysis

(requires Option AYA, vector modulation analysis)

Signal acquisition	
Modulation format	Auto detect or manual override (BPSK, QPSK, 16 QAM, 64 QAM)
Search length (minimum search length is result length + 24 μ s)	Adjustable between 66 and 6800 symbol-times; 264 μ s to 27 ms.
Result length	Auto detect or adjustable between 1 and 1367 symbol-times
Triggering	Single/continuous, free-run, channel, external
Measurement region	Interval and offset adjustable within result length

Signal playback	
Result length	Auto detect or adjustable between 1 and 1367 symbol-times
Capture length (gap-free analysis at 0% overlap and 31.25 MHz span)	0.125 seconds (standard) 1.0 seconds (Option 144) 2.0 seconds (Option 288) 8.0 seconds (Option 001)

Supported formats	
Formats	IEEE 802.11a, HiperLAN2
Single-button presets	IEEE 802.11a, HiperLAN2

Other adjustable parameters	
IQ Normalize	On/Off
Subcarrier Spacing	Continuously adjustable
Symbol Timing Adjust	Adjustable between 0 and Guard Interval
Guard Interval	1/4, 1/8 (HiperLAN2 only)
Pilot Tracking	Optionally phase, optionally amplitude, optionally timing
Carriers to Analyze	All or Single Carrier

Demodulation measurement results	
IQ measured	All carriers over all symbol-times
IQ reference	All carriers over all symbol-times (ideal, computed from detected symbols)
Error vector	Time, Spectrum (vector difference between measured and reference)
RMS error vector	Time, Spectrum
Common pilot error	At all symbol-times
Symbol table and error summary	Summary of EVM, pilot EVM, common pilot error (CPE), IQ offset, freq error, short sync correlation, number of symbols, modulation format, code rate, bit rate

Equalizer measurement results	
(Shows effects of PSA IF flatness if left uncorrected)	
Equalizer impulse response (computed from preamble)	
Channel frequency response (computed from preamble)	

Pre-demodulation measurement results	
Time	
Spectrum	Instantaneous, Averaged
Search time	

Display formats

The following trace formats are available for measured data and computed ideal reference data, with complete marker and scaling capabilities and automatic grid line adjustment to ideal symbol or constellation states.

Polar diagrams

Constellation	Samples displayed only at symbol times
Vector	Display of trajectory between symbol times with 1–20 points/symbol

I or Q versus time

Eye diagrams	Adjustable from 0.1 to 40 symbols
Trellis diagrams	Adjustable from 0.1 to 40 symbols
Continuous error vector magnitude versus time	
Continuous I or Q versus time	

Error displays

Error vector spectrum	Error values for each symbol-time plotted for each carrier
Error vector time	Error values for each carrier plotted for each symbol-time

Residual EVM (independent of modulation format) -40 dB max
(RMS average count = 20)

Frequency error (relative to frequency standard)

Lock range	± 625 kHz
Accuracy	± 10 Hz

Center frequency leakage (residual) -60 dB

Equalizer coefficients derived from channel estimation sequence

Appendix 1 Configuration overview

There are two possible configurations for using a PSA series performance spectrum analyzer as a downconverter for an 89600 series VSA:

Configuration 1

- PSA series analyzer with firmware revision A.02.01 or later and special Option H70 (70 MHz IF output)
- 89611A VSA with software version 3.00 or later, and with Option AYA (vector modulation analysis) and Option B7R (802.11 and HiperLAN2 OFDM modulation analysis)
- PC with
 - IEEE 1394 interface to communicate with and control the 89611A
 - LAN or GPIB interface to communicate with and control the spectrum analyzer

This configuration uses special Option H70 to provide a 70 MHz IF output from the spectrum analyzer directly to the 89611A 70 MHz IF vector signal analyzer. In this configuration, the VSA can control the setup of the spectrum analyzer via a point-to-point LAN or network connection, or a direct GPIB connection. See Figures 1a and 1b.

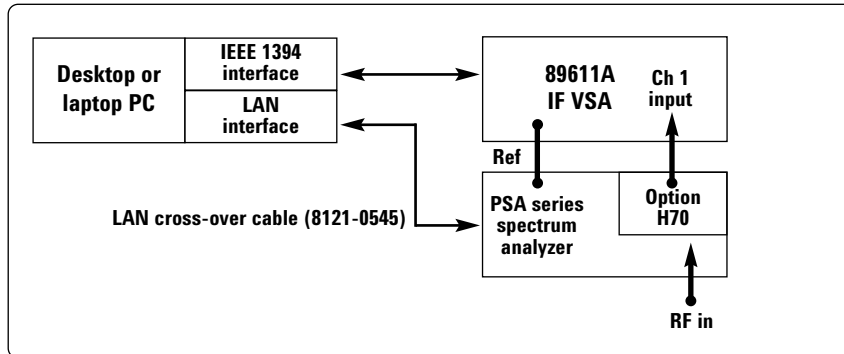

Figure 1a. PSA series analyzer with 89611A and point-to-point LAN connection. The PC and the spectrum analyzer may also be connected to a multipoint LAN network.

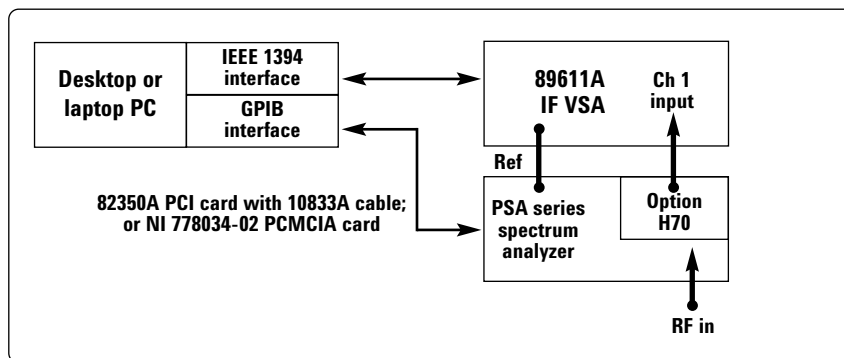

Figure 1b. PSA series spectrum analyzer with 89611A and GPIB connection to PC.

Configuration 2

- PSA series analyzer with firmware revision A.02.01 or later
- 89640A VSA with software version 3.00 or later, and with Option AYA (vector modulation analysis) and Option B7R (802.11a and HiperLAN2 OFDM modulation analysis)
- PC with IEEE 1394 interface to communicate with and control the 89640A.

This configuration uses the standard 321.4 MHz IF output available on the PSA series analyzers. This input is fed directly into the 89640A dc to 2.7 GHz VSA. Note that no control of the spectrum analyzer is available. The user can, however, configure the display software on the VSA to properly reflect the current RF center frequency and span. See Figure 2.

Compatible PSA series spectrum analyzers

The PSA series performance spectrum analyzers that support Option H70 are shown in Table 1.

E4440A	3 Hz to 26.5 GHz
E4443A	3 Hz to 6.7 GHz
E4445A	3 Hz to 13.2 GHz

Table 1. Compatible PSA series spectrum analyzers.

PC for 89600 series VSA software

A laptop or desktop PC may be used as long as it meets the following requirements:

Minimum requirements for a user-supplied desktop PC:

- 180 MHz Pentium, or AMD-K6 CPU (>300 MHz CPU recommended)
- One empty PCI-bus slot (2 slots recommended)
- 192 MB RAM (256 MB recommended)
- 4 MB video RAM (8 MB recommended)
- Hard disk with 100 MB available space

- Microsoft Windows NT 4.0 (Service Pack 5 or greater required) or Windows 2000
- CD-ROM drive (can be provided via network access)
- 3.5-inch floppy disk drive (can be provided via network access)

Minimum requirements for a user-supplied laptop PC:

- > 300 MHz Pentium, or AMD-K6 CPU
- One empty Cardbus Type II slot (2 slots recommended)
- 192 MB RAM (256 MB recommended)
- 4 MB video RAM (8 MB recommended)
- Microsoft Windows 2000
- CD-ROM drive (can be provided via network access)
- 3.5-inch floppy disk drive (can be provided via network access)
- Supported IEEE 1394-1995 interface (may not be available in all areas worldwide). For a list of supported interfaces, go to www.agilent.com/find/iolib or contact your local Test and Measurement Call Center or sales office.

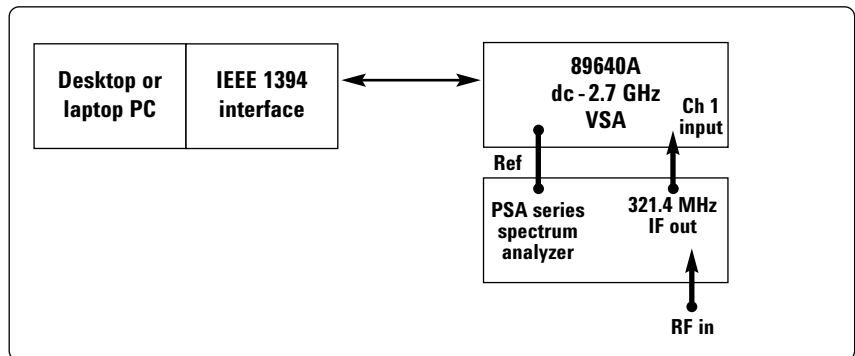

Figure 2. PSA series spectrum analyzer used as downconverter for the 89640A. Control of the spectrum analyzer is manual. The 89600 series software running on the PC can properly annotate the display for frequency range, and measurement techniques exist for calibrating the measurement path.

Agilent Technologies Test and Measurement Support, Services, and Assistance

Agilent Technologies aims to maximize the value you receive, while minimizing your risk and problems. We strive to ensure that you get the test and measurement capabilities you paid for and obtain the support you need. Our extensive support resources and services can help you choose the right Agilent products for your applications and apply them successfully. Every instrument and system we sell has a global warranty. Support is available for at least five years beyond the production life of the product. Two concepts underlie Agilent's overall support policy: "Our Promise" and "Your Advantage."

Our Promise

Our Promise means your Agilent test and measurement equipment will meet its advertised performance and functionality. When you are choosing new equipment, we will help you with product information, including realistic performance specifications and practical recommendations from experienced test engineers. When you use Agilent equipment, we can verify that it works properly, help with product operation, and provide basic measurement assistance for the use of specified capabilities, at no extra cost upon request. Many self-help tools are available.

Your Advantage

Your Advantage means that Agilent offers a wide range of additional expert test and measurement services, which you can purchase according to your unique technical and business needs. Solve problems efficiently and gain a competitive edge by contracting with us for calibration, extra-cost upgrades, out-of-warranty repairs, and on-site education and training, as well as design, system integration, project management, and other professional engineering services. Experienced Agilent engineers and technicians worldwide can help you maximize your productivity, optimize the return on investment of your Agilent instruments and systems, and obtain dependable measurement accuracy for the life of those products.

By internet, phone, or fax, get assistance with all your test and measurement needs

**Online assistance:
www.agilent.com/find/assist**

Phone or Fax

United States:

(tel) 1 800 452 4844

Canada:

(tel) 1 877 894 4414

(fax) (905) 282-6495

China:

(tel) 800 810 0189

(fax) 1 0800 650 0121

Europe:

(tel) (31 20) 547 2323

(fax) (31 20) 547 2390

Japan:

(tel) (81) 426 56 7832

(fax) (81) 426 56 7840

Korea:(tel) (82 2) 2004 5004

(fax) (82 2) 2004 5115

Latin America:

(tel) (305) 269 7500

(fax) (305) 269 7599

Taiwan:

(tel) 080 004 7866

(fax) (886 2) 2545 6723

Other Asia Pacific

Countries:

(tel) (65) 375 8100

(fax) (65) 836 0252

Email: tm_asia@agilent.com

Product specifications and descriptions in this document subject to change without notice.

© Agilent Technologies, Inc. 2001

Printed in USA, October 29, 2001

5988-4094EN

